

This article was downloaded by:

On: 22 January 2011

Access details: *Access Details: Free Access*

Publisher *Taylor & Francis*

Informa Ltd Registered in England and Wales Registered Number: 1072954 Registered office: Mortimer House, 37-41 Mortimer Street, London W1T 3JH, UK



The Journal of Adhesion

Publication details, including instructions for authors and subscription information:

<http://www.informaworld.com/smpp/title~content=t713453635>

The Study of Fiber-Matrix Interactions Via FT-IR Microscopy and NMR Imaging

A. Mavrich^a; F. Fondueur^a; H. Ishida^a; J. L. Koenig^a; H. D. Wagner^b

^a Department of Macromolecular Science, Case Western Reserve University, Cleveland, Ohio, USA ^b Department of Materials and Interfaces, The Weizmann Institute of Science, Rehovot, Israel

To cite this Article Mavrich, A. , Fondueur, F. , Ishida, H. , Koenig, J. L. and Wagner, H. D.(1994) 'The Study of Fiber-Matrix Interactions Via FT-IR Microscopy and NMR Imaging', *The Journal of Adhesion*, 46: 1, 91 – 102

To link to this Article: DOI: 10.1080/00218469408026652

URL: <http://dx.doi.org/10.1080/00218469408026652>

PLEASE SCROLL DOWN FOR ARTICLE

Full terms and conditions of use: <http://www.informaworld.com/terms-and-conditions-of-access.pdf>

This article may be used for research, teaching and private study purposes. Any substantial or systematic reproduction, re-distribution, re-selling, loan or sub-licensing, systematic supply or distribution in any form to anyone is expressly forbidden.

The publisher does not give any warranty express or implied or make any representation that the contents will be complete or accurate or up to date. The accuracy of any instructions, formulae and drug doses should be independently verified with primary sources. The publisher shall not be liable for any loss, actions, claims, proceedings, demand or costs or damages whatsoever or howsoever caused arising directly or indirectly in connection with or arising out of the use of this material.

The Study of Fiber-Matrix Interactions Via FT-IR Microscopy and NMR Imaging*

A. MAVRICH, F. FONDEUR, H. ISHIDA and J. L. KOENIG**

*Department of Macromolecular Science, Case Western Reserve University,
Cleveland Ohio, 44106, USA*

H. D. WAGNER

*Department of Materials and Interfaces, The Weizmann Institute of Science,
Rehovot 76100, Israel*

(Received December 3, 1992; in final form March 29, 1993)

Model composites of Kevlar-49® and D-glass fiber/epoxy systems were analyzed using NMR imaging and FT-IR microscopy. The surfaces of both reinforcing agents were found to affect the curing process of the epoxy significantly. The NMR images reveal an accelerated rate of cure in the proximity of the fibers as compared with the bulk, indicating strong interactions between the fibers and the matrices. To characterize these interactions spectroscopically, FT-IR microscopy was performed on Kevlar-reinforced microcomposites. Transmission spectra and IR functional group images reveal a preferential segregation of the epoxy resin to the fiber surface. Thin films of epoxy resin deposited on single Kevlar filaments were also examined using FT-IR microscopy. Spectra and IR images from these samples suggest that the amine group of the Kevlar fiber is reacting with the epoxide ring of the resin to catalyze the curing process.

KEY WORDS NMR imaging; FT-IR microscopy; Kevlar-49; epoxy resin; curing; IR functional group image; interphase/interface; composites.

INTRODUCTION

The performance of a fiber-reinforced composite is dependent on the integrity of the fiber-matrix interphase. Thus, to design a composite with optimal properties, a better understanding of the fiber-matrix interactions is necessary. Modern vibrational spectroscopic techniques can play an active role in developing superior composites by characterizing the interphase of these systems. In doing so, specific tailoring of the interphase can produce a high performance fiber-matrix composite.

Modern surface techniques such as RAIR, ATR, SERS and XPS have been used to analyze the interphase in a variety of adhesive systems.¹⁻³ Such techniques have significantly increased the understanding of interphases, specifically their structure-

*Presented at the International Symposium on "The Interphase" at the Sixteenth Annual Meeting of The Adhesion Society, Inc., Williamsburg, Virginia, U.S.A., February 21–26, 1993.

**Corresponding author.

property relationships. However, detailed spectroscopic information about the spatially-distributed components in these interphases is lacking. Presently, chemical degradation of adhesive films on composites and metal oxides, along with the segregation of molecules at the interphase, can be detected with FT-IR microscopy.⁴⁻⁵ FT-IR microscopy, with a resolution better than 10 μm , allows detailed analysis of the spatial distribution of chemical species.

In this study, localized infrared microscopy was used in conjunction with NMR imaging to characterize the interphase and specific fiber-matrix interactions of fiber-reinforced composites, namely Kevlar-49[®]/epoxy and rod (D-) glass/epoxy systems. The use of these modern spectroscopic techniques provides a better understanding of those engineering factors which influence the interphase structure.

EXPERIMENTAL

Model fiber/epoxy composites were designed for NMR and FT-IR analysis. The reinforcing agents were "Kevlar-49" (a para-aramid fiber from Du Pont) and D-glass (Pyrex[™] rod 7740 glass from Corning). The epoxy resin was DER 331[®], a bisphenol-A based liquid resin from Dow Chemical Company, with an average epoxy equivalent weight of 189. The resin was mixed in stoichiometric proportions with an aliphatic polyamine curing agent, DEH 26 (tetraethylenepentamine), with an amine hydrogen equivalent weight of 27.0.

A Bruker MSL 300 spectrometer equipped with a 15 mm micro-imaging probe was used to acquire images at a proton frequency of 300 MHz. All images were taken at room temperature and displayed as 256×256 pixels in size. The pulse sequence used was a T_1 coupled with a standard Carr-Purcell⁶ spin-echo with non-selective 90-degree pulses for the T_1 , a selective 90-degree pulse, and a non-selective 180-degree pulse with CYCLOPS phase cycling. Typical duration times for the 90-degree and 180-degree pulses were 60 and 113 μs , respectively. A recycling delay of one second was used between pulse sequence repetitions. Magnetic field gradients were 9–10 Gauss/cm in the in-plane space and 2–3 Gauss/cm in the z-direction. The proton of the methyl unit in the *gem*-dimethyl was imaged.

All IR spectra were obtained in transmission mode using an IR μS [™]/SIRM Molecular Microanalysis System from Spectra-Tech Inc. The system consists of a Scanning Infrared Microprobe with a liquid-nitrogen-cooled, narrow-band MCT detector and Redundant Aperturing[®] to mask the fiber specimens for minimal diffraction and stray light effects. The microscope is also equipped with a 32X IR/visible reflecting Cassegrain objective and a 10X duplex Cassegrain condenser which were used in this study. Triangular apodization was applied and interferograms were transformed with 8192 points with no zero filling. The acquired spectra were then transferred to a Microvax III+ computer system for further processing.

Single Kevlar fibers ranged in diameter from 12 to 15 μm , whereas the D-glass rods had an outer diameter of 2 mm. Three single strands of Kevlar (25 filaments per strand) were braided to an effective diameter of 1 mm. The braiding produced a more pronounced geometry and prevented the filaments from fanning apart when the uncured epoxy was added. The braided fibers were threaded through a glass tube (13 mm I.D. \times 45 mm long) enclosed at both ends with plastic caps and stretched for

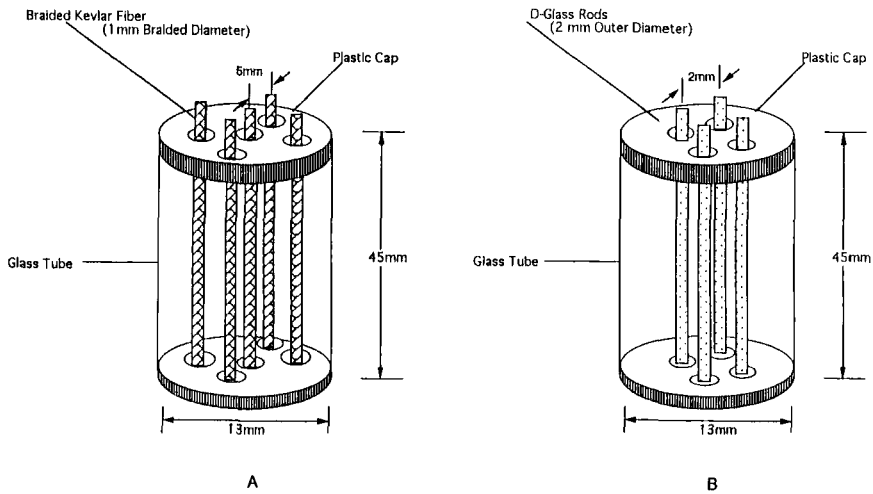

FIGURE 1 Schematic illustrating the sample set up for (A) Kevlar-49 fibers and (B) D-glass fibers used in the NMR imaging experiment.

alignment. The braids were arranged 5 mm apart in a cross-type pattern shown in Figure 1A. The D-glass rods were inserted in a similar manner with 2 mm between each rod (Figure 1B). Next, the tubes were filled with uncured epoxy, after which NMR imaging was performed as a function of cure time.

Microcomposite samples, approximately 15 μm thick, were prepared at the Materials and Interfaces laboratory at the Weizmann Institute of Science in Rehovot, Israel. These microcomposites are model unidirectional composites made of single Kevlar filaments precisely positioned and aligned in an epoxy matrix with a cure schedule of 7 days at 25°C, followed by postcure of 2 h at 60°C.⁷⁻⁸ Details of the sample preparation technique can be found in References 7 and 8. The sample dimensions were 5 mm \times 35 mm with an inter-fiber distance of 500 μm (Figure 2).

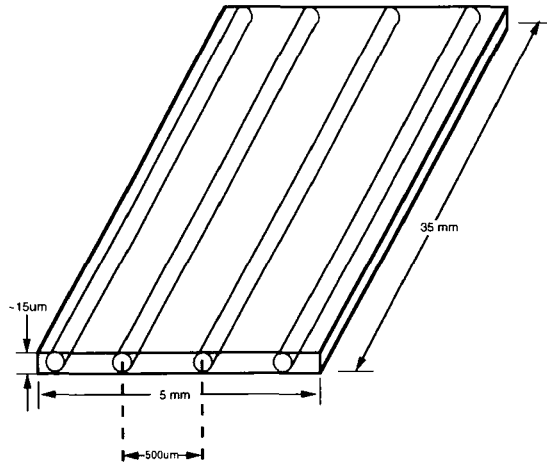

FIGURE 2 Illustration of the Kevlar-49/epoxy microcomposite.

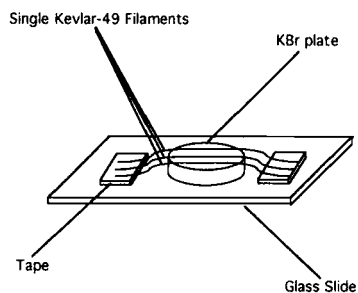

FIGURE 3 Single filaments of Kevlar-49 aligned on a KBr plate on which a thin film of epoxy resin was cast.

Localized transmission spectroscopy was performed on these samples using a $6\ \mu\text{m} \times 120\ \mu\text{m}$ upper-variable aperture and a lower-variable aperture of the same dimensions. The samples were then scanned 50 times at a resolution of $4\ \text{cm}^{-1}$. Also, an IR mapping experiment was performed using a $24\ \mu\text{m} \times 24\ \mu\text{m}$ upper- and lower-variable aperture with the same resolution and number of scans.

To monitor any fiber/resin interactions at the interphase, thin films of epoxy resin were deposited on single filaments of Kevlar-49. Each filament was carefully extracted from segments of yarn and then aligned on a KBr plate (Figure 3). A thin film of DER 331 epoxy resin was cast from an acetone solution onto the KBr plate. Finally, this sample was mounted onto the motorized IR microscope stage and localized transmission spectra were obtained using $24\ \mu\text{m} \times 24\ \mu\text{m}$ square apertures.

RESULTS AND DISCUSSION

NMR imaging of the samples revealed specific inhomogeneities related to varying degrees of cure. Contrast in the images is due to spatial differences in T_2 originating from different degrees of cure. The intensity at a given pixel reflects the cured state of the sample at that location. Resolution of the NMR images was $244\ \text{Hz}/\text{pixel}$ in the x-direction. However, line broadening limits the resolution of the NMR image. The line width at 0.2 and 0.8 hours of cure was 51 and 189 Hz, respectively. Hence, the images obtained yielded a digital resolution of $32\ \mu\text{m}$ per pixel.

Figures 4 and 5 are NMR images obtained from the Kevlar and D-glass samples, respectively. The intensity of the images illustrates levels of cure; red indicates areas of high mobility or uncured domains while blue represents low mobility or cured domains. Both images shown in Figure 4 are displayed at the same selected gray level range. The lower cut-off level selected was 45 with an upper cut-off level of 105. The gray scale was then expanded using the upper and lower cut-off gray levels to maximize the range resulting in the same data windowing for both images. The same procedure was performed for the images shown in Figure 5.

Image A in Figure 4 shows yellow intensity levels in the area around the fiber indicating a higher level of cure than the red bulk. Image B (105 minutes later)

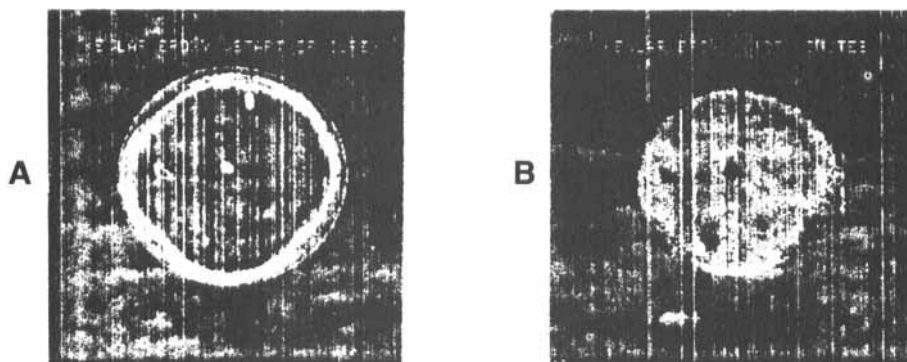

FIGURE 4 NMR images of braided Kevlar fibers in epoxy. Image A was taken at the start of cure. Image B was taken 105 minutes into the curing process. Red areas are representative of levels of high mobility or uncured states while the blue areas are indicative of low mobility or cured states. See Color Plate III.

shows those same yellow areas as being dark blue, indicating complete cure. Also, in the regions slightly further from the fiber, a darker blue is observed in comparison with the bulk indicating again a higher level of cure but still not yet completely cured.

Image A in Figure 5 shows basically the same trend as in Figure 4. The dark blue circles giving no signal are the glass rods. Around the rods are light blue and yellow intensity levels indicating a higher level of cure in comparison with the red bulk. In image B, the light blue regions have changed to a dark blue, indicating complete cure. At the same time, the yellow regions from image A have changed to light blue or green levels where a higher level of cure is evident in comparison with the bulk.

These images reveal an accelerated cure rate in the proximity of the fibers as compared with the bulk, indicating strong interactions between the fiber and the matrix. It appears that certain functional groups at the surface of the fibers are catalyzing the cure reaction of the epoxy. This effect also suggests that the spatial distribution of the cured domains is dictated by the geometry, surface chemis-

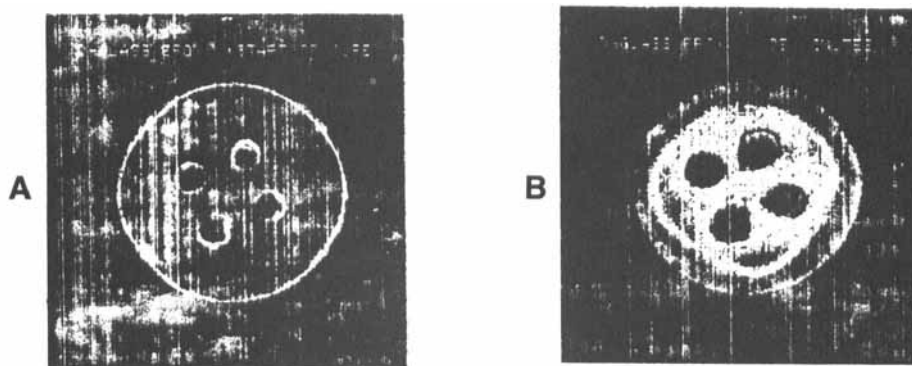
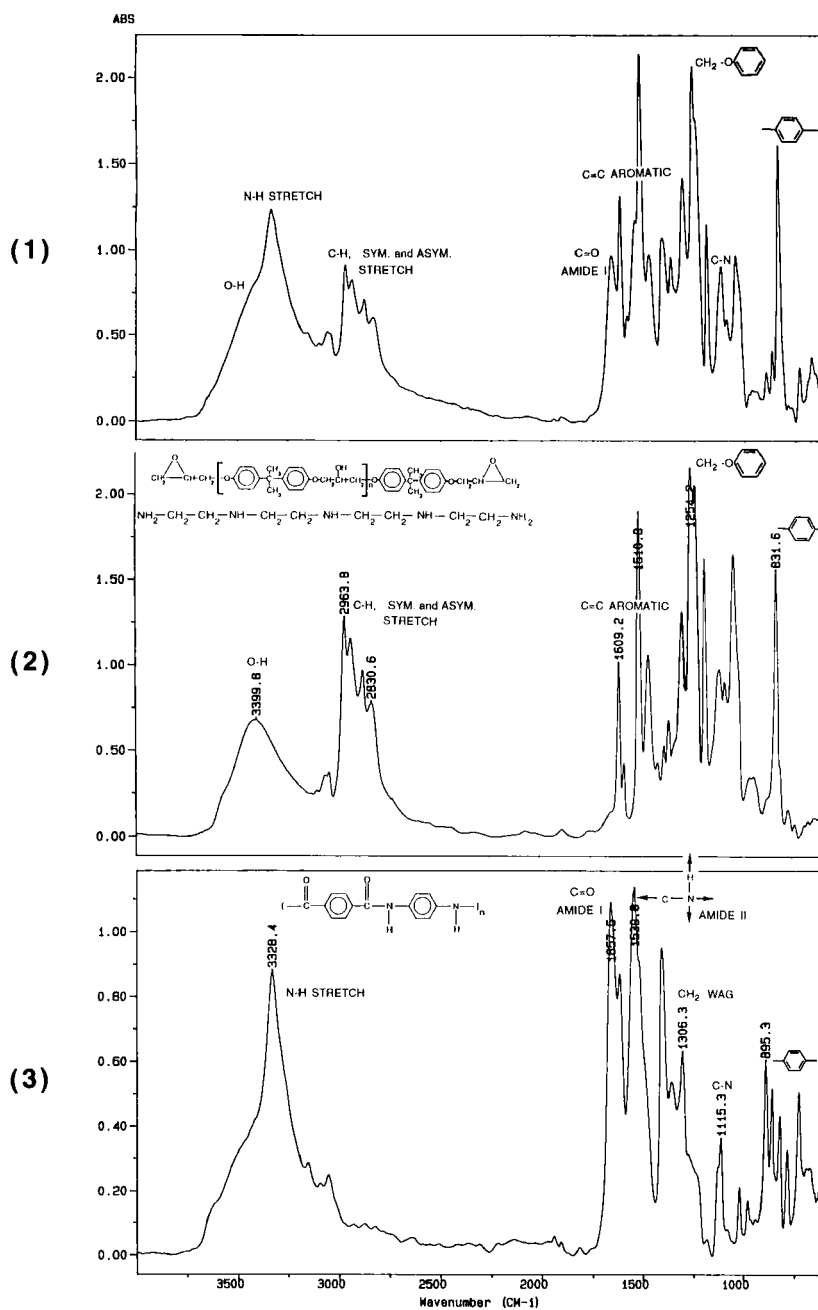

FIGURE 5 NMR images of D-glass rods in epoxy. Image A was taken at the start of cure. Image B was taken 105 minutes into the curing process. See Color Plate IV.



A

FIGURE 6A Transmission spectra of (1) single filament of Kevlar-49 embedded in an epoxy matrix, (2) bulk matrix approximately 30 μm to right of position (1), and (3) Kevlar-49 in air.

**B**

FIGURE 6B (TOP) Kevlar-49/epoxy spectrum (1), (MIDDLE) spectrum containing sum of the scaled pure components (2) and (3), (BOTTOM) difference spectrum generated by least squares iterations.

try and/or surface roughness of the fibers. The NMR images of the Kevlar and D-glass/epoxy systems also reveal evidence of advanced cure around the glass tube surface. This is most likely due to contaminants or adsorbed water on the glass surface.

FT-IR microscopy of Kevlar-49 reinforced epoxy microcomposites reveals specific interactions between the matrix and the fiber. To characterize these interactions spectroscopically, transmission spectra were obtained of (1) the fiber embedded within the matrix (2) bulk matrix approximately 30 μm right of the fiber center and (3) a single filament of Kevlar-49 in air. An automatic spectral subtraction program, which utilizes an iterative least squares procedure to optimize the scaling factor, was used to extract the two pure components (bulk matrix and Kevlar-49) from the fiber/epoxy spectrum. This resulted in a difference spectrum characteristic of the interphase (Figures 6 and 7). It should be mentioned here that special care was taken in aperturing each sample and sample area similarly, in each case, to keep the diffraction effects more equal. This was done to prevent the appearance of residuals that can occur from spectral subtractions not done under the above men-

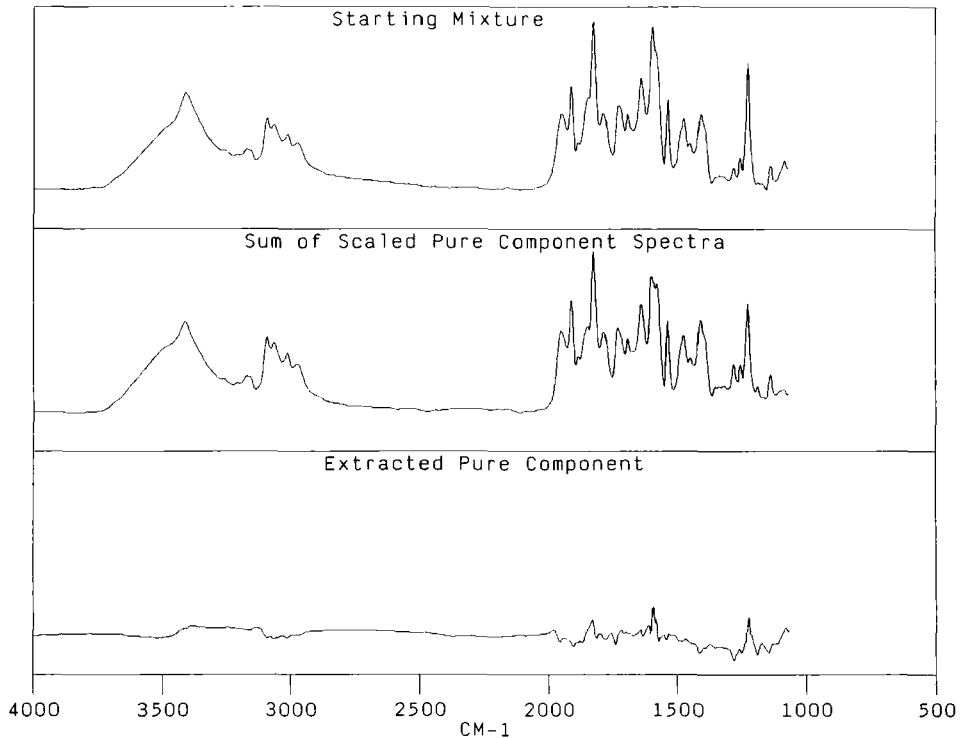
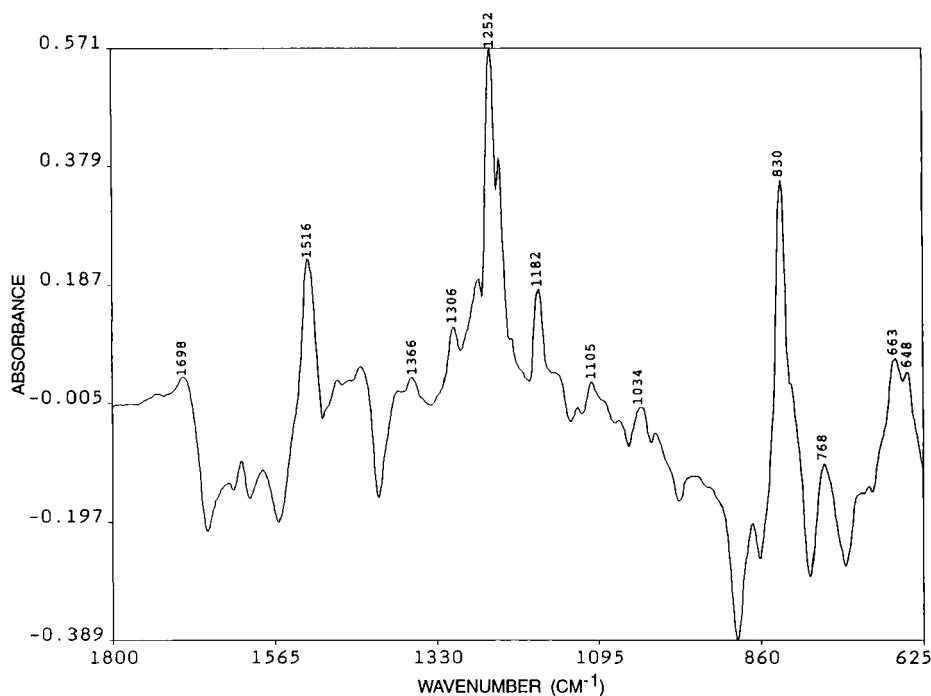

FIGURE 7 Subtraction spectrum of Kevlar-49/epoxy minus bulk matrix and pure Kevlar for the frequency region 2000–600 cm^{-1} .

tioned conditions. Some of the subtractions obtained showed traces of remaining residuals. At the same time, however, more accurate qualitative differences were obtained with good reproducibility.

The difference spectrum (Figure 7) is dominated by strong bands near 1516, 1252, and 830 cm^{-1} . These bands are characteristic of aromatic carbon vibrations originating from functional groups present in the epoxy resin. The 1516 and 1252 cm^{-1} bands are related to the C=C aromatic stretching and C—O aromatic ether asymmetrical out-of-phase bending of the resin, respectively. These bands are consistent with vibrational frequency assignments of bisphenol-A-based epoxy resins given by Carter *et al.*³ The 830 cm^{-1} peak is characteristic of para-substituted C—H wagging along with the band found at 768 cm^{-1} . Weaker bands near 1698, 1366, 1306, 1105, and 1034 cm^{-1} were observed at the interphase. The vibrational assignments of these peaks are summarized in Table I.

The difference spectrum, shown in Figure 7, indicates an attraction as well as a preferential segregation of the epoxy resin at the fiber surface. To monitor this segregation, a mapping experiment was performed on a 60 μm^2 area of a microcomposite containing a single Kevlar fiber (Figure 8). IR functional group images were obtained from the mapping experiment for the 1516 and 1252 cm^{-1} peaks (Figure 9) which were found earlier to be prevalent at the interphase. Images A and B are contour maps of the 1516 and 1252 cm^{-1} peaks, respectively. These images display preferentially-segregated domains of higher intensity at the fiber surface in compar-

TABLE I
Tentative peak assignments of the Kevlar-49/epoxy interphase

Wavenumber (cm^{-1})	Vibrational assignment
1698*	disubstituted amide $\text{R}-\text{CO}-\text{NR}_2$
1366	$\text{C}-(\text{CH}_3)$ methyl deformation
1306*	possible ester
1105	aromatic $\text{C}-\text{C}$ and $\text{C}(\text{CH}_3)$ skeletal
1034	para-disubstituted benzene
768	para-disubstituted benzene

*Peaks unique to interphase

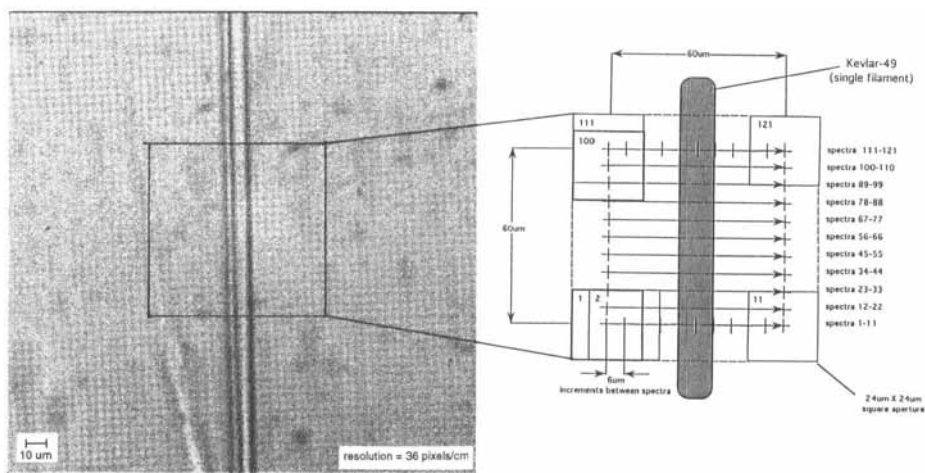

FIGURE 8 Digital image of a single filament of Kevlar-49 aligned in an epoxy matrix microcomposite. Outlined is the area in which the mapping experiment was performed. All spectra were obtained in transmission with 50 scans at a resolution of 4 cm^{-1} . Shown, to scale, is the $24 \mu\text{m} \times 24 \mu\text{m}$ square aperture used to obtain each spectrum with $6 \mu\text{m}$ increments between each.

ison with the bulk. Based on these images, the resin appears to be attracted to the fiber surface.

To understand this attraction better, thin films of epoxy resin were deposited on the surface of single Kevlar filaments. A mapping experiment was then performed on one of the fibers. All spectra obtained from the mapping experiment were normalized to a constant thickness. The IR functional group image in Figure 10A is a contour map of the 916 cm^{-1} peak, representing the $\text{C}-\text{H}$ deformation of the epoxide ring. This peak was chosen to monitor any interactions between the epoxide ring in the resin and the amine group in the fiber. Lower intensities appear along the fiber surface, suggesting sites along the fiber where the epoxide had ring opened and had begun to cross-link. Using the same mapping experiment data, a pixel map was generated; this is shown in Figure 10B. The color scale in image B illustrates levels of IR intensities. Red indicates areas of highest intensity while blue represents

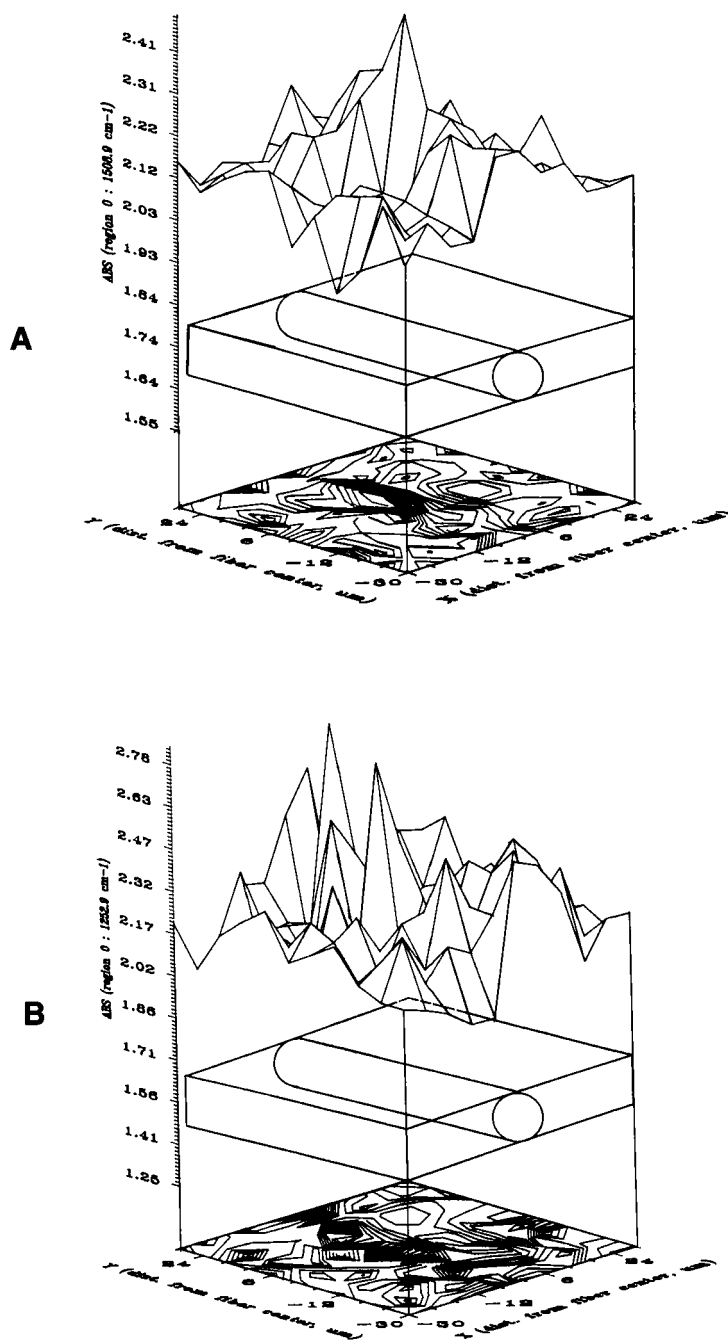

FIGURE 9 IR functional group images showing the preferential segregation of the resin to the fiber surface. Image A is a contour map of the 1509 cm^{-1} peak which is the C=C aromatic stretch of the resin. Image B is a contour map of the 1252 cm^{-1} peak which is the C—O aromatic ether asymmetrical out of phase bending. Notice areas of high intensity along the fiber surface in comparison to the bulk.

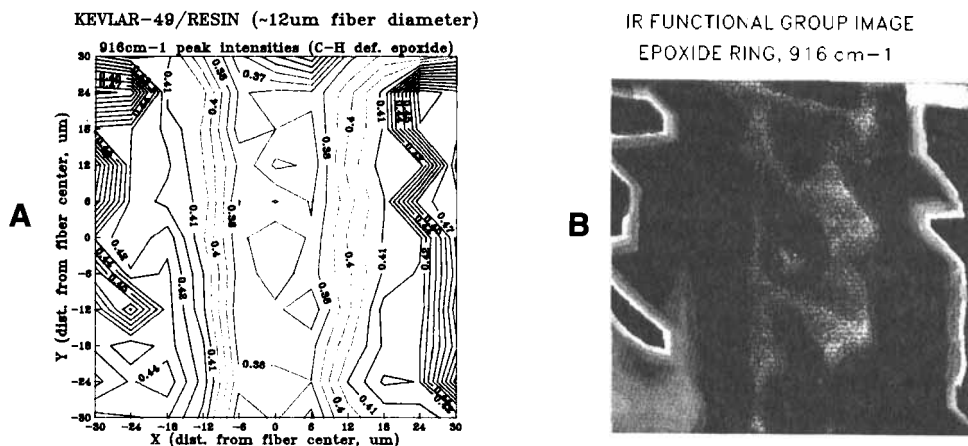
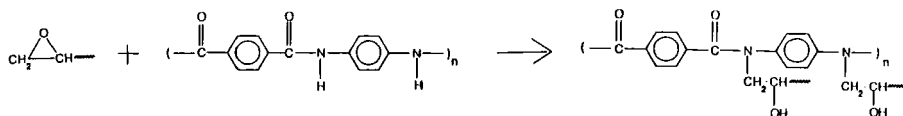
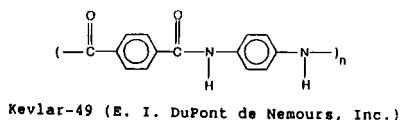
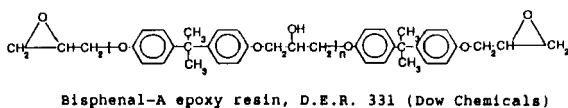

FIGURE 10 IR functional group images obtained after normalizing each spectrum in the mapping experiment to constant thickness. Image A is a contour map while image B is a pixel map of the C—H deformation of the epoxide ring, 916 cm^{-1} . See Color Plate V.

areas of lowest intensity. This IR image shows more clearly the segregated sites (blue regions) along the surface of the fiber where the resin has begun to cross-link. Based on these two IR functional group images, the amine group of the fiber appears to be curing the resin in much the same fashion as the curing agent (Scheme 1). This explains the accelerated rate of cure at the fiber surface in the NMR images. The amine group of the Kevlar fiber may be working in conjunction with the amine group of the curing agent to cross-link the system, resulting in an accelerated cure rate at the fiber. In the bulk, only the curing agent is present, resulting in a slower rate of cure.



SCHEME 1

CONCLUSIONS

The surfaces of both Kevlar-49 and D-glass fibers were found to affect the curing process in composite samples significantly. Such effects were clearly illustrated with the use of NMR imaging. The NMR images obtained in this study revealed nonuniform cure of the matrix in Kevlar-49 and D-glass fiber reinforced composites. The epoxy was found to cure at an accelerated rate at the surface of these fibers indicating strong interaction between the fibers and the matrices. With the application of FT-IR microscopy, these interactions were found to be preferential segregation of the epoxy on the Kevlar surface. It was also determined that the amine group of the Kevlar fiber acted to catalyze the curing process.

Acknowledgements

The authors would like to thank the Office of Naval Research for their financial support under grant No. N0001492J1047.

References

1. D. J. Obrus, F. J. Boerio and K. J. Grannen, *J. Adhesion* **29**, 32–41 (1989).
2. F. J. Boerio, P. P. Hong, P. J. Clark and Y. Okamoto, *Langmuir* **6**(4), 721–7 (1989).
3. R. O. Carter III, C. A. Gierzak and R. A. Dickie, *Appl. Spectroscopy* **40**(5), 649–55 (1986).
4. F. Fondeur and J. L. Koenig, *Appl. Spectroscopy* **47**(1), 1–6 (1993).
5. F. Fondeur and J. L. Koenig, *J. Adhesion* **40**, 189 (1993).
6. H. Y. Carr and E. M. Purcell, *Phys. Rev.* **94**, 630 (1954).
7. H. D. Wagner and L. W. Steenbakkens, *J. Mater. Sci.* **24**, 3956 (1989).
8. H. D. Wagner, M. Rubins and G. Marom, *Polymer Composites* **12**(4), 233 (1991).